

M404 - Waveform Generator

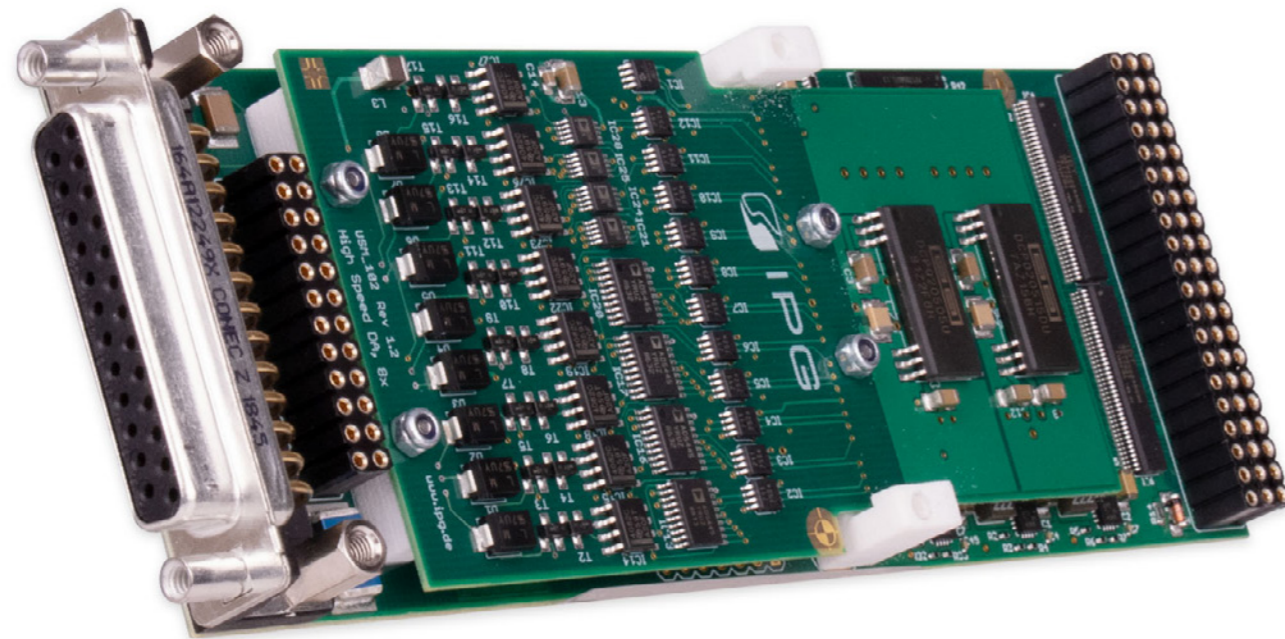

Features

- 4 independent high speed waveform generators
- 4 independent low speed waveform generators
- Maximum output frequency: 1.75 MHz for high speed channels, 435 kHz for low speed channels
- Frequency resolution: 0.00035 Hz
- 2 arbitrary waveforms for each channel, each defined by 64 k 12 bit-words, adjustable gain
- Fast switching between the waveforms
- Weighted intermixing of both tables of a channel
- Adjustable gain
- Output voltage range: -10V .. +10V
- Output voltage res.: 12bit, corresponding to 4,8mV
- Perfectly designed for usage with passive wheel-speed sensor simulation for trucks
 - Simulation of loosing and missing teeth
 - Wheel angle resolution: 0.0055deg
 - Wheel rotation speed resolution: 0.021rpm
 - Maximum wheel rotation speed: 50,000rpm
- Galvanic isolation
- In the field hardware upgrade by updating the FPGA

Use Cases

- Emulating passive wheel speed sensor signals in truck ABS/ESC test applications
- Testing fail-safe mechanisms by simulation of missing teeth
- Generating arbitrary waveforms

Block Diagram

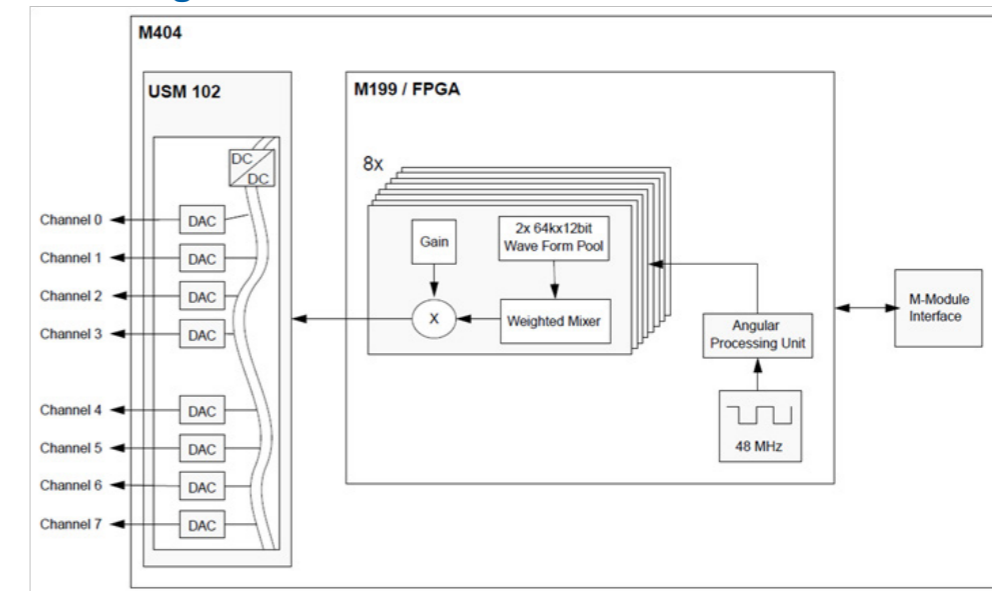

Technical Data

Output channels	<ul style="list-style-type: none"> • 4 independent high speed waveform generators • 4 independent low speed waveform generators
Output voltage range	-10V .. +10V
Output voltage resolution	12bit (corresponds to 4,8mV)
Output current per channel	<ul style="list-style-type: none"> • 20mA with internal supply • 85mA with external supply (optional)
Maximum output frequency	<ul style="list-style-type: none"> • 1.75MHz for high speed channels • 435kHz for low speed channels (depending on user waveform)
Frequency resolution	0.00035Hz (depending on user waveform)
Waveform table size	64k 12bit words (each table)
Number of waveform tables	2 for each channel
Sample rate	<ul style="list-style-type: none"> • 3.5MHz for high speed channels • 875kHz for low speed channels
Address space	<ul style="list-style-type: none"> • A08D16 • A24D32
Available connectors	25 Pin SubD connector, female

Order Information

Order Number	IO-M404
--------------	---------

Alternatives

M400	For generation of active wheel speed sensor signals
------	---